

**ERGO LINE
AFFINITY 700**

**ADVANCED
PERFORMANCE**

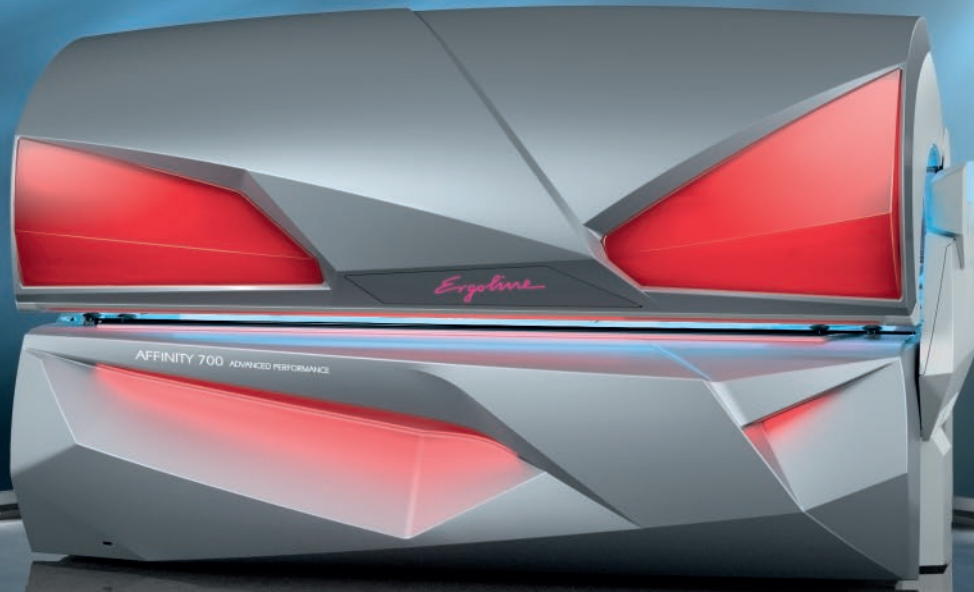

ERGO LINE AFFINITY 700 ADVANCED PERFORMANCE

AFFINITY FOR PERFORMANCE

- **ADVANCED PERFORMANCE WITH 46 UV LAMPS AND 3 FACIAL TANNERS**
- **LED LIGHT SHOW – A NEW HIGHLIGHT IN YOUR SALON**
- **LED INTERIOR LIGHT – BRIGHTLY ILLUMINATED INTERIOR**
- **AIR CONDITION PLUS – ENJOY A COOL AND PLEASANT TEMPERATURE**
- **NEW CONTROL PANEL – FOR COMPLETE EASE OF OPERATION**



*Minimum quantities may be required for customs designs. Ask your Ergoline representative for details.

Ergoline

HIGHLIGHTS

AFFINITY 700 ADVANCED PERFORMANCE

LUXURY FEATURES

ADVANCED

46 x 160 W

With the latest UV technologies, Ergoline is the world leader in commercial tanning. Advanced Performance delivers a deep and seamless tan with 46 UV body lamps.

ULTRA

3 x 500 W

Ultra Performance Plus technology with glass reflectors includes UV-B spaghetti lamps and special filters. It is the most advanced facial system on the market today.

7 x 25 W

The shoulder tanners provide additional tanning performance to the top of your shoulders, for a perfect all-around tan.

LED LIGHT SHOW

High quality performance LED's guarantee impressive color brilliance with more than 200 colors and light effects. It features up to 80% energy savings and an operating life of more than 30,000 hours.

INTERIOR LIGHT

The new LED interior light emphasizes the features in the tanning tunnel. The brightly illuminated tanning tunnel appears particularly hygienic and invites your customers to tan.

COMFORT COOLING+

Comfort Cooling PLUS wraps your body and face in a pleasant flow of cooling air. The ventilation for face and body automatically ensures the right climate.

BODY SHAPE

Our Body Shape base acrylic on all Affinity models lets you relax in comfort whether you are lying on your back or your front.

3D SOUND

Our 3D-Sound System will bathe you in a sumptuous sea of sound as you tan. The system consists of two speakers, a subwoofer, and an SD card slot and MP3 connection.

MP3 AUX

With this function you can connect a MP3 player or a smartphone to enjoy your own music during the session. The Auto Play function will recognize the connection automatically.

VOICE GUIDE

Voice Guide walks you through every step in a pleasant, friendly voice as you control the tanning bed.

AIR CONDITION+

The new Air Condition PLUS cools the base acrylic and promises an overall refreshing feeling during the tanning session.



ERGOLINE AFFINITY 700

ADVANCED PERFORMANCE

Lamps	Watts max.	FT	Watts max.
46	160	3	500
UV-B	Watts	ST	Watts
2	8	7	25

Maximum exposure schedule: 12 minutes

Features:

Advanced Performance, Ultra Performance PLUS, LED Light Show, Interior Light, Body Shape, Air Condition PLUS, Comfort Cooling PLUS, Shoulder Tan includes 3D-Sound unit*

*3D-Sound unit includes Voice Guide, MP3 & iPod connection, SD-Card-Slot Automatic Volume and Auto Play.

AIR SUPPLY AND EXTRACTION SYSTEMS, TECHNICAL SPECS, DIMENSIONS AND DATA

GENERAL

- Automatic temperature-adjusted centralized ventilation
- Dimensions closed (L x W x H in inches): 93 x 54 x 56
- Dimensions open (H in inches): 69
- Minimum cabin dimensions (L x W in feet): 9 x 8

ELECTRICAL SPECS

- Total power input at 230 V mains voltage: 13,700 watts (12,600 w/o AC)
- Electrical requirements: 230V 3Ø or 230V 1Ø
- Circuit breaker recommended: 50A/3-pole or 80A/2-pole
- Weight: approx. 1,173 lb

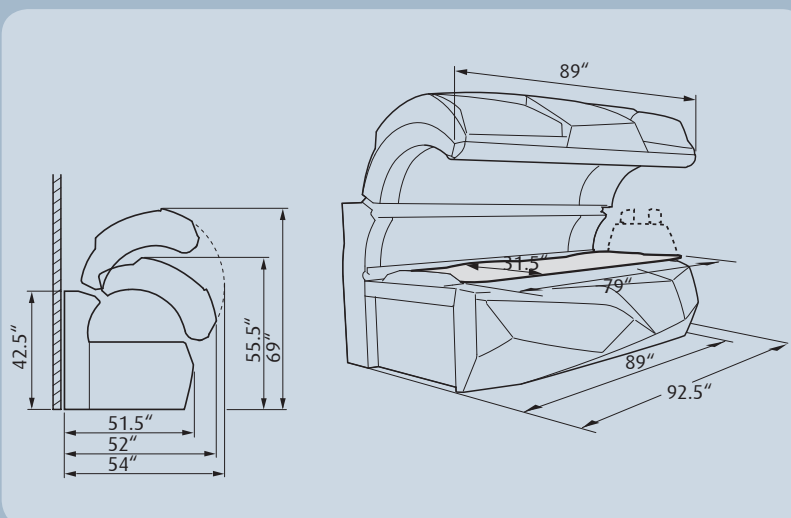

Contraindication: This product is contra indicated for use on persons under the age of 18 years.

Contraindication: This product must not be used if skin lesions or open wounds are present.

Warning: This product should not be used on individuals who have had skin cancer or have a family history of skin cancer.

Warning: Persons repeatedly exposed to UV radiation should be regularly evaluated for skin cancer.

Notice: Read the mandatory FDA warning label found on every tanning machine for important information on potential eye injury, skin cancer, skin aging and photosensitive reaction and proper use. Compliant protective eyewear must be worn when using any indoor tanning system or device.

© 2014 JK Products & Services, Inc. reserves the right to change product designs, features, specifications, etc. without notice.

ERGOLINE, A DIVISION OF JK PRODUCTS & SERVICES, INC.

411 W Washington Ave. Suite B · Jonesboro, AR 72401

888.771.0996 www.ergoline.us

www.facebook.com/JKProductsUS

Ergoline